



Thunder Sky

Address: Winston Industrial Park, Third Industrial Zone, Lisonglang Village,
Gongming Town, Shenzhen, Guangdong P.R.C
Tel: +86-755-8602 6789 Fax: +86-755-8602 6678
Http: //www.winston-battery.com E-mail: winston@Chung.tw

雷天牌稀土鋰動力電池性能說明 SPECIFICATION FOR THUNDER SKY RARE EARTH LITHIUM POWER BATTERY



單體電池尺寸 DIMENSIONS

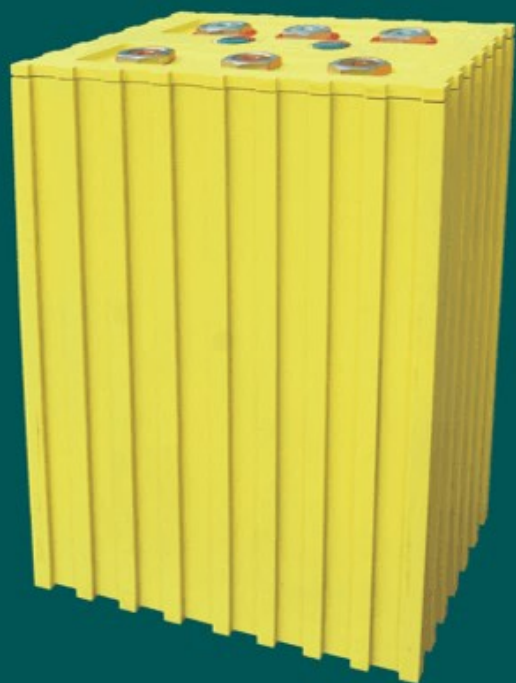

型号(MODEL): TS-LTHP750AHA

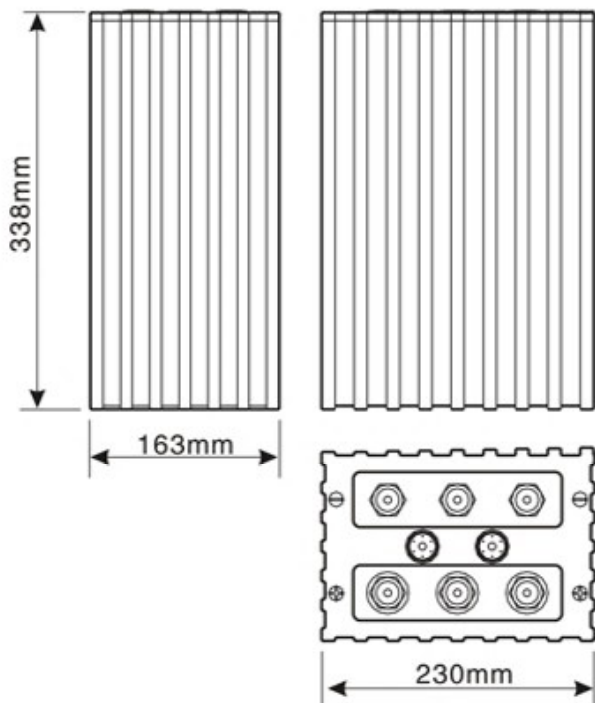

技術參數 SPECIFICATIONS

型号(MODEL): TS-LTHP750AHA

標稱容量 Nominal Capacity	750Ah	
工作電壓 Operation Voltage	充電 (Charge)	4.5V
	放電 (Discharge)	2.5V
最大充電電流 Max Charge Current	≤3CA	
最大放電電流 Max Discharge Current	恒電流 (Constant Current)	≤ 3CA
	脈衝式 (Impulse Current)	≤ 10CA
標準充放電電流 Standard Charge/Discharge Current	0.5CA	
循環壽命 Cycle Life	(85DOD%)	≥5000Times
	(75DOD%)	≥7000Times
殼體耐溫性 Temperature Durability Of Case	≤200°C	
適應環境 Operating Temperature	充電 (Charge)	-45°C~85°C
	放電 (Discharge)	-45°C~85°C
自放電率(月) Self-discharge Rate	≤3%(Monthly)	
單體電池重量 Weight	17.0kg ± 500g	